

# BOLLARD, CAP, CHAIN, 4.5" - BOL-CC-4.5-RF

APPROX WEIGHT: 6 lbs.  
DOES NOT INCLUDE WEIGHT OF POWER OR PACKAGING!!!

\*\*\* ANY ADDITIONS, DELETIONS, OR OMISSIONS MUST BE CORRECTED ON THIS DRAWING AS THIS DRAWING WILL BE CONSIDERED ALL INCLUSIVE \*\*\*

ALL GRAPHICS PROVIDED ARE FOR REFERENCE ONLY. IF CERTAIN DIMENSIONS ARE CRITICAL PLEASE VERIFY THOSE DIMENSIONS WITH YOUR SALESPERSON

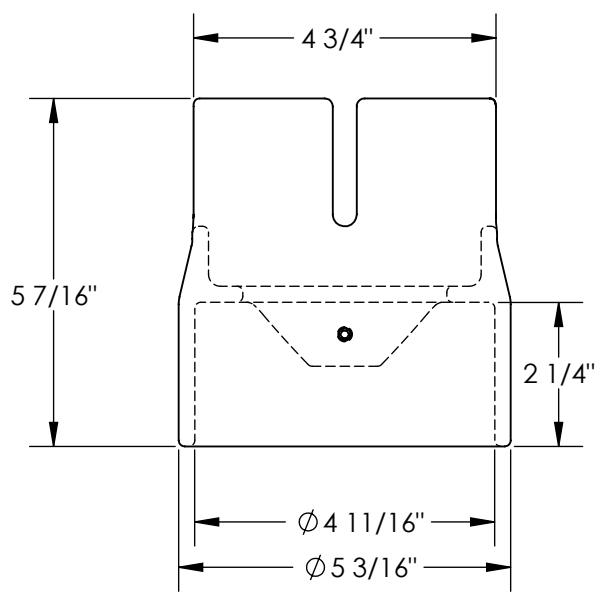

NOTE: SET SCREW INCLUDED

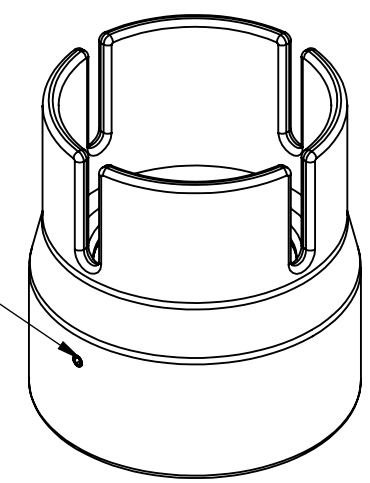

## STANDARD FEATURES

- MODEL NUMBER IS BOL-CC-4.5-RF
- OUTSIDE DIAMETER IS 5 3/16"
- INSIDE DIAMETER IS 4 11/16"
- OVERALL HEIGHT IS 5 7/16"
- INSERTION HEIGHT IS 2 1/4"
- FOR USE ON 4 1/2" BOLLARDS
- MATERIAL IS CAST STEEL
- FINISH IS BRIGHT ZINC PLATED

## SPECIAL FEATURES

NONE

DIMENSION TOLERANCE  $\pm 1/4$ "

|   |  |                                    |
|---|--|------------------------------------|
| <b>A<br/>P<br/>P<br/>R<br/>O<br/>V<br/>A<br/>L</b>                  | I, THE UNDERSIGNED, AGREE THAT THE PRODUCT AS REPRESENTED SATISFIES DESIGN AND DIMENSION REQUIREMENTS. I ALSO ACKNOWLEDGE MY DUTY TO CONFIRM PRODUCT AND INSTALLATION COMPLIANCE WITH ALL APPLICABLE FEDERAL, STATE AND LOCAL REGULATIONS AND STANDARDS. |                                    |
|   | <b>UNITS REQUIRING APPROVAL DRAWINGS OR MODIFIED ARE NON-RETURNABLE</b>  |                                    |
|   | <input type="checkbox"/> As drawn  | <input type="checkbox"/> As marked |
|   | Signed: _____ Date: _____  |                                    |
|   | Printed Name: _____  |                                    |
| <i>LEAD TIME WILL START UPON RECEIPT OF SIGNED APPROVAL DRAWING</i> |  |                                    |

|                      |            |            |
|----------------------|------------|------------|
| DISTRIBUTOR'S NAME:  |            | P.O.#      |
| VESTIL MANUFACTURING |            | X          |
| DRAWN BY: NBE        |            | W.O.#      |
| DATE: 4/13/20        |            | X          |
| REFERENCE: X         | SCALE: 1:3 | SALES: X   |
| QUOTED LEAD TIME: X  | QUOTE #    | FILE NAME: |
|                      | X          | 23-007-725 |